

Wall Mounted Shower Drencher (Round)

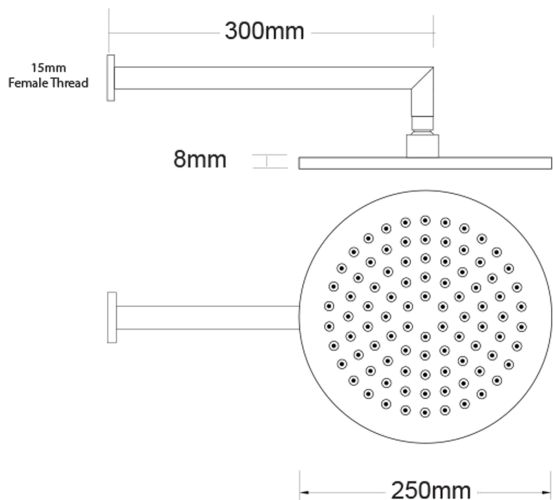

PRODUCT CODE

NRT81RWBB

COLOUR/FINISHES

Brushed Nickel (PVD)
Brushed Brass (PVD)
Brushed Gunmetal (PVD)
Matte Black
Chrome

PRESSURE TYPE

All Pressures

MIN. PRESSURE

35kPa

MAX. PRESSURE

500kPa (As per NZ Building Code AS/NZ 3500.1)

MAX. TEMPERATURE

65°C

PLUMBING CONNECTION

15mm

WELS RATING

Low/Unequal 2 Star; 10L/min
Mains 3 Star; 6.5L/min

SHOWER HEAD SIZE

250 x 250mm

ARM LENGTH

300mm

Specifications and dimensions are subject to change without notice.

Installation instructions are available from the product page on www.foreno.co.nz

BUILDING CODE CLAUSES RELEVANT TO THIS PRODUCT:
Clause G12 Water Supplies, specifically G12.3.5, G12.3.6, and G12.3.7. www.foreno.co.nz/building-code-clauses/

This product is not subject to a warning or ban under section 26 of the Building Act 2004.